

# INTERLACER

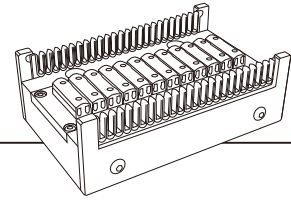

## インターレーサー 网络器

合成繊維は、フィラメントがバラバラにならない様に、ある程度収束させる必要が有ります。その目的の為に使用されるのが、インターレーサーです。ノズルから圧縮空気を噴出する事でフィラメント同士を絡ませてあげる装置です。糸の太さ(規格)や求められる交絡(均一性・強度・数量)に合わせて最適な製品を提案させていただきます。表面には、丸みのある梨地仕上を施す事も可能ですので、摩擦抵抗を低減させたり糸へのダメージを最小限に抑える事も可能です。

合成繊維在后道加工及使用过程中需要长丝具有一定的集束性。网络器便是一种通过网络加工让长丝的单丝之间产生相互缠绕达到一定程度集束效果的装置。我们可以根据客户的纤维规格及需要的网络效果(均匀度, 强度, 网络结数)来推荐合适的网络器产品。根据需要, 我们的网络器零件表面还可进行低摩擦处理, 使网络加工过程中零件对纤维的损伤降到最低。

No./図番 C106030



MATERIAL/材質 YM-99C

weight/重量 62.0g

SURFACE/表面仕上げ NF DP HF HF2

D/NO.	φd	φc
C106030-J	1.3	6.0
C106030-L	1.6	6.0
C106030-P	2.0	8.0
C106030-T	2.4	8.0
C106030-W	3.0	8.0

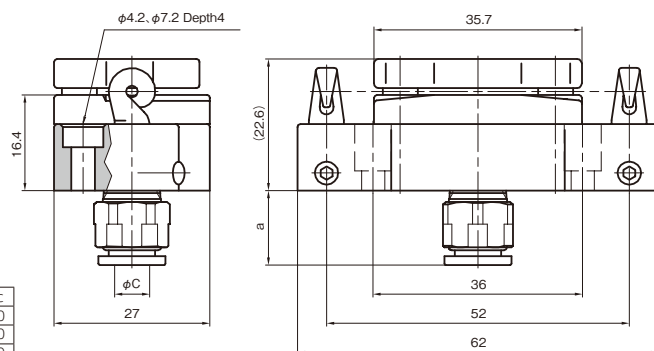

No./図番 C204030



MATERIAL/材質 YM-99C

weight/重量 37.0g

SURFACE/表面仕上げ NF DP HF HF2

D/NO.	φd
C204030-G	1.1
C204030-H	1.2
C204030-J	1.4
C204030-L	1.6

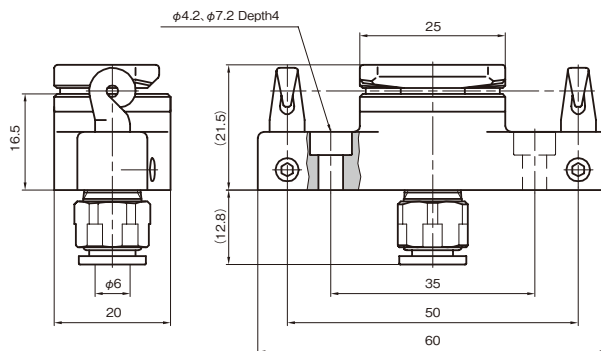

No./図番 D905030



MATERIAL/材質 YM-99C

weight/重量 77.0g

SURFACE/表面仕上げ NF DP HF HF2

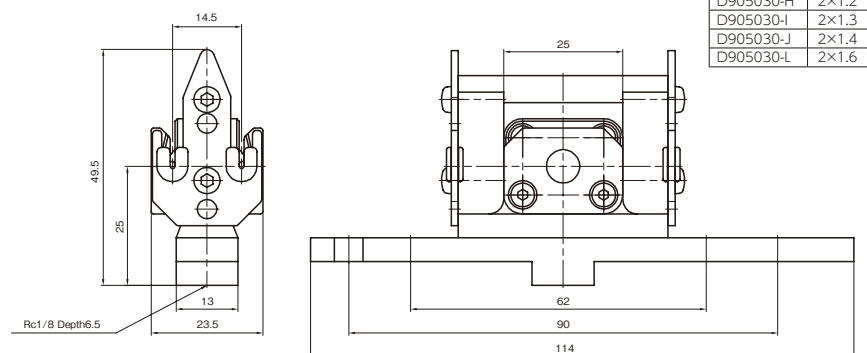

**No./図番** D007002



**MATERIAL/材質** YM-99C

**weight/重量** 20.4g

**SURFACE/表面仕上げ** NF DP HF HF2

MIGRATION NOZZLE  
マイグレーションノズル

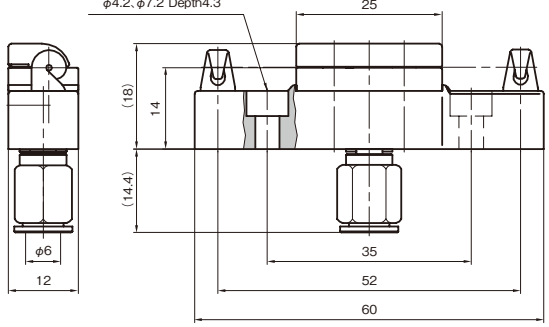

HF2仕様=D003037-I(G-K)

D/NO.	φd
D007002-G	1.1
D007002-I	1.3
D007002-K	1.5

**No./図番** D306030



**MATERIAL/材質** YM-99C

**weight/重量** 21.0g

**SURFACE/表面仕上げ** NF DP HF HF2

MIGRATION NOZZLE  
マイグレーションノズル

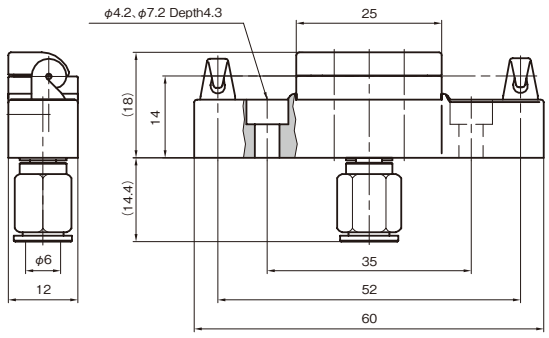

HF2仕様=D202060-I(G-K)

D/NO.	φd
D306030-G	1.1
D306030-I	1.3
D306030-J	1.4
D306030-K	1.5

**No./図番** D412006



**MATERIAL/材質** YM-99C

**weight/重量** 33.0g

**SURFACE/表面仕上げ** NF DP HF HF2

MIGRATION NOZZLE  
マイグレーションノズル

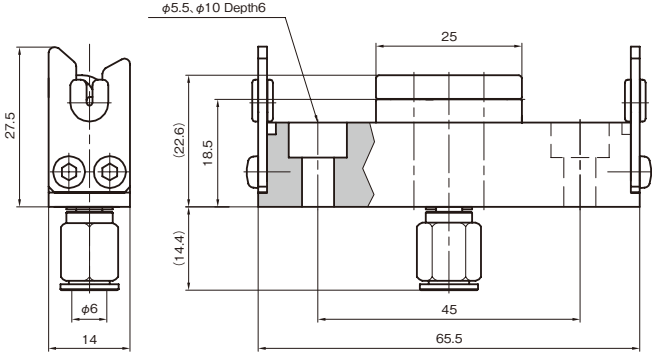

HF2仕様=F004049-I(G-J)

D/NO.	φd
D412006-G	1.1
D412006-I	1.3
D412006-J	1.4

**No./図番** D512002



**MATERIAL/材質** YM-99C

**weight/重量** 38.2g

**SURFACE/表面仕上げ** NF DP HF HF2

MIGRATION NOZZLE  
マイグレーションノズル

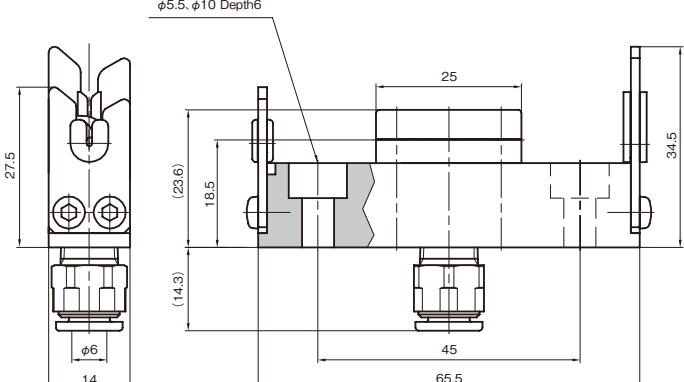

HF2仕様=D806036-K(L-N)

D/NO.	φd
D512002-K	1.5
D512002-L	1.6
D512002-N	1.8

- OLING GUIDE-INTER LACER
- TRAVERSE GUIDE
- SNAIL GUIDE-DOG TAIL GUIDE
- HOOK GUIDE-SLIT GUIDE
- TWIST STOP WHEEL
- ROLLER GUIDE
- CREEL PARTS
- GUIDE etc.
- BEARING ROLLER GUIDE
- BAR GUIDE-PIPE GUIDE
- EYELET GUIDE-TUBE GUIDE
- TENSION WASHER
- BOBBIN CAP
- TENSOR
- YARN SENSOR
- OTHER

# INTERLACER インターレーサー 网络器

No./図番 **D304099**



MATERIAL/材質 **YM-99C**

weight/重量 **29.9g**

SURFACE/表面仕上げ **NF DP HF HF2**

D/NO.	φd
D304099-G	1.1
D304099-I	1.3

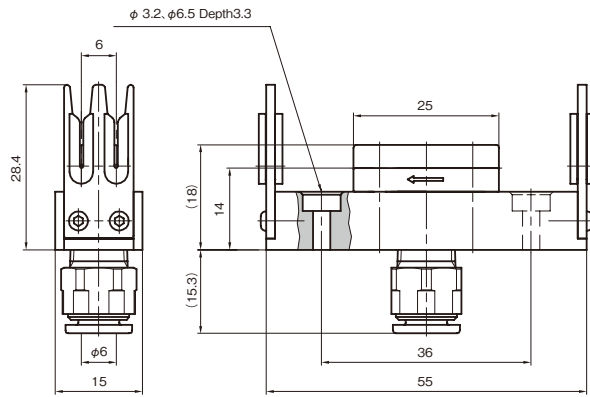

HF2仕様=D302069-I(G)

No./図番 **D505005**



MATERIAL/材質 **YM-99C**

weight/重量 **41.7g**

SURFACE/表面仕上げ **NF DP HF HF2**

D/NO.	φd
D505005-G	1.1
D505005-I	1.3
D505005-K	1.5

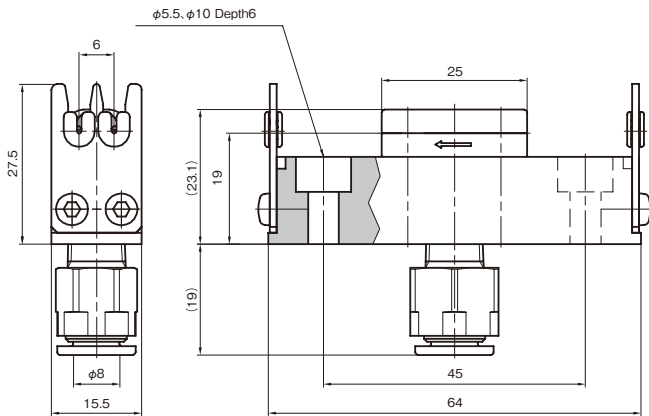

HF2仕様=F004050-I(G·K)

No./図番 **D508035**



MATERIAL/材質 **YM-99C**

weight/重量 **31.4g**

SURFACE/表面仕上げ **NF DP HF HF2**

D/NO.	φd
D508035-G	1.1
D508035-I	1.3

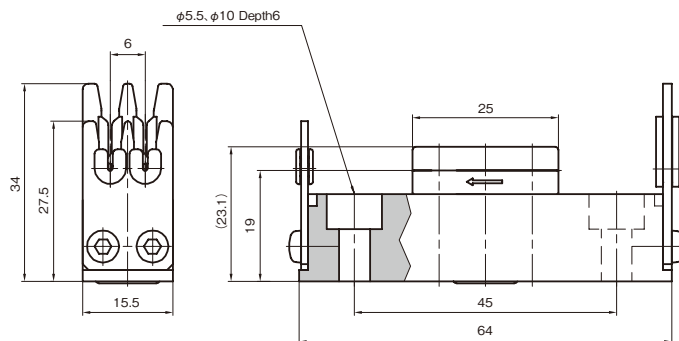

HF2仕様=F004051-I(G)

No./図番 **D608128**



MATERIAL/材質 **YM-99C**

weight/重量 **41.6g**

SURFACE/表面仕上げ **NF DP HF HF2**

D/NO.	φd
D608128-G	1.1
D608128-I	1.3
D608128-K	1.5

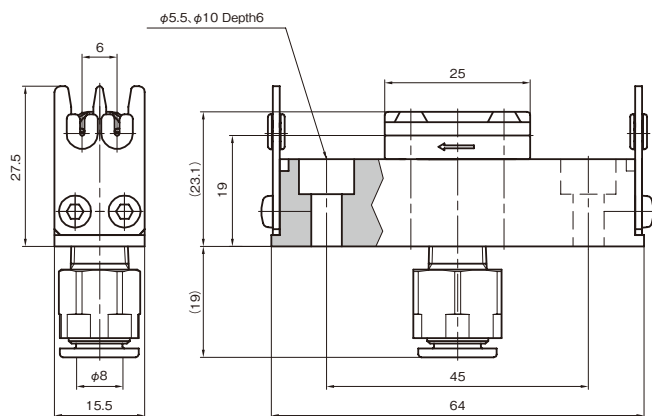

HF2仕様=F004052-I(G·K)

OLING GUIDE- INTER LACER  
TRVERSE GUIDE  
SNAIL GUIDE- DOG TAIL GUIDE  
HOOK GUIDE- SLIT GUIDE  
TWIST STOP WHEEL  
ROLLER GUIDE  
CREEL PARTS  
GUIDE etc.  
BEARING GUIDE  
BAR GUIDE- PIPE GUIDE  
EYELET GUIDE- TUBE GUIDE  
TENSION WASHER  
BOBBIN CAP  
TENSOR  
YARN SENSOR  
OTHER

**No./図番** F204022



**MATERIAL/材質** YM-99C

**weight/重量**

**SURFACE/表面仕上げ** NF DP HF HF2

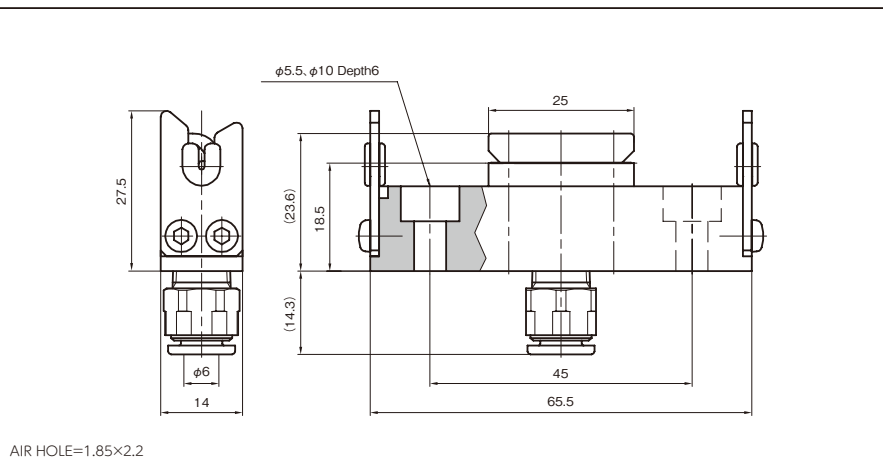

**No./図番** F106002



**MATERIAL/材質** YM-99C

**weight/重量** 35.0g

**SURFACE/表面仕上げ** NF DP HF HF2

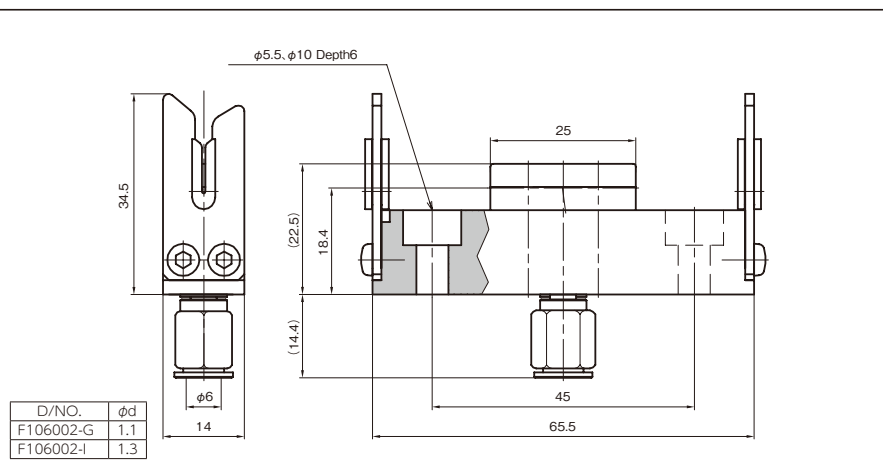

**No./図番** F009030



**MATERIAL/材質** YM-99C

**weight/重量** 43.0g

**SURFACE/表面仕上げ** NF DP HF HF2

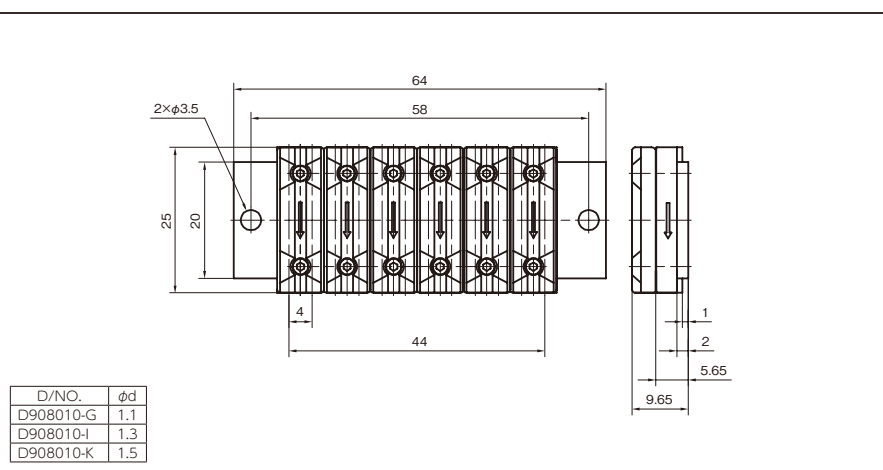

**No./図番** D807017



**MATERIAL/材質** YM-99C

**weight/重量** 124.5g

**SURFACE/表面仕上げ** NF DP HF HF2

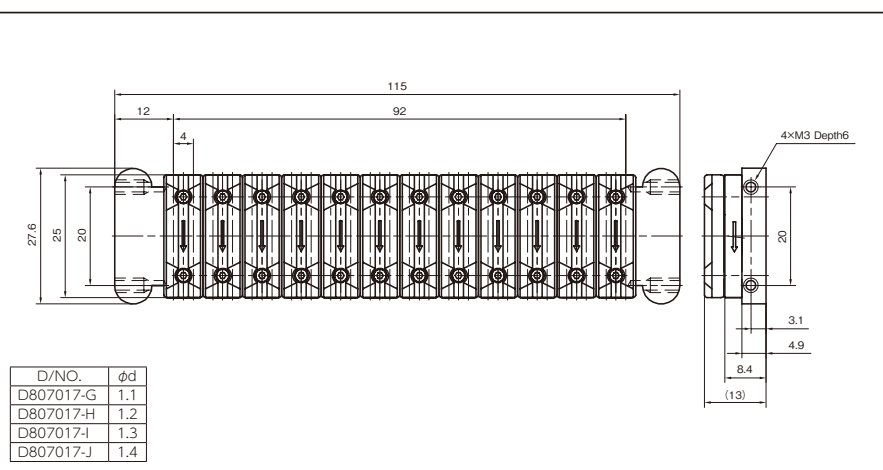

- TRaverse GUIDE
- SNAIL GUIDE-DOG TAIL GUIDE
- HOOK GUIDE-SLIT GUIDE
- TwIST STOP WHEEL
- ROLLER GUIDE
- CREEL PARTS
- GUIDE etc.
- BEARING ROLLER GUIDE
- BAR GUIDE-PIPE GUIDE
- EXLET GUIDE-TUBE GUIDE
- TENSION WASHER
- BOBBIN CAP
- TENSOR
- YARN SENSOR
- OTHER

# INTERLACER インターレーサー 网络器

OLING GUIDE-  
INTER LACER

TRAVERSE  
GUIDE

SNAIL GUIDE-  
DOG TAIL GUIDE

HOOK GUIDE-  
SLIT GUIDE

TWIST STOP  
WHEEL

ROLLER GUIDE

CREEL PARTS

GUIDE etc.

BEARING  
ROLLER GUIDE

BAR GUIDE-  
PIPE GUIDE

EYELET GUIDE-  
TUBE GUIDE

TENSION  
WASHER

BOBBIN CAP

SENSOR

YARN SENSOR

OTHER

No./図番 **F102006**

Pitch=4mm



D/NO.	φd
F102006-G	1.1
F102006-H	1.2
F102006-I	1.3
F102006-J	1.4
F102006-K	1.5

MATERIAL/材質 **YM-99C**

SURFACE/表面仕上げ NF DP HF **HF2**

No./図番 **D909099**

Pitch=4mm



D/NO.	φd
D909099-G	1.1
D909099-H	1.2
D909099-I	1.3
D909099-J	1.4
D909099-K	1.5

MATERIAL/材質 **YM-99C**

SURFACE/表面仕上げ NF DP HF **HF2**

No./図番 **D905015**

Pitch=4mm

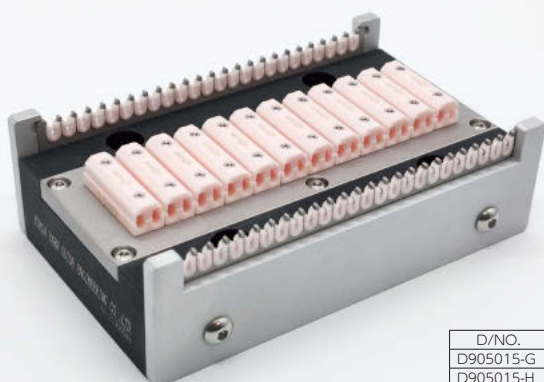

D/NO.	φd
D905015-G	1.1
D905015-H	1.2
D905015-I	1.3
D905015-J	1.4
D905015-K	1.5

MATERIAL/材質 **YM-99C**

SURFACE/表面仕上げ NF DP HF **HF2**

No./図番 **F101011**

Pitch=4mm

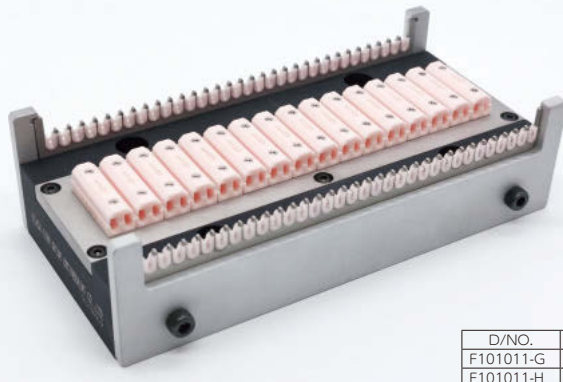

D/NO.	φd
F101011-G	1.1
F101011-H	1.2
F101011-I	1.3
F101011-J	1.4
F101011-K	1.5

MATERIAL/材質 **YM-99C**

SURFACE/表面仕上げ NF DP HF **HF2**

No./図番 **D903056**

Pitch=4mm

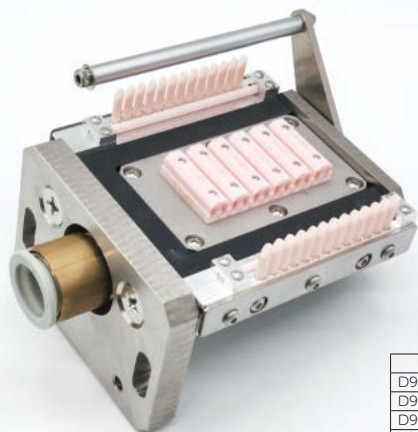

D/NO.	φd
D903056-G	1.1
D903056-H	1.2
D903056-I	1.3
D903056-J	1.4
D903056-K	1.5

MATERIAL/材質 **YM-99C**

SURFACE/表面仕上げ NF DP HF **HF2**

No./図番 **F102025**

Pitch=6mm

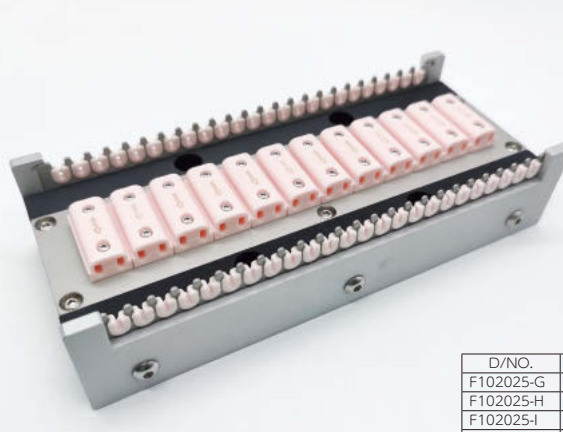

D/NO.	φd
F102025-G	1.1
F102025-H	1.2
F102025-I	1.3
F102025-J	1.4
F102025-K	1.5

MATERIAL/材質 **YM-99C**

SURFACE/表面仕上げ NF DP HF **HF2**