

INTERLACER

インターレーサー／网络器

合成繊維は、フィラメントがバラバラにならない様に、ある程度収束させる必要が有ります。その目的の為に使用されるのが、インターレーサーです。ノズルから圧縮空気を噴出する事でフィラメント同士を絡ませてあげる装置です。糸の太さ(規格)や求められる交絡(均一性・強度・数量)に合わせて最適な製品を提案させていただきます。表面には、丸みのある梨地仕上げを施す事も可能ですので、摩擦抵抗を低減させたり糸へのダメージを最小限に抑える事も可能です。

合成繊維在后道加工及使用过程中需要长丝具有一定的集束性。网络器便是一种通过网络加工让长丝的单丝之间产生相互缠绕达到一定程度集束效果的装置。我们可以根据客户的纤维规格及需要的网络效果(均匀度, 强度, 网络结数)来推荐合适的网络器产品。根据需要, 我们的网络器零件表面还可进行低摩擦处理, 使网络加工过程中零件对纤维的损伤降到最低。

図番 /No. **C106030**



D/NO.	φd	φC	α
C106030-I	1.3	6.0	13
C106030-L	1.6	6.0	13
C106030-T	2.0	8.0	17
C106030-P	2.4	8.0	17
C106030-W	3.0	8.0	17

重量 /WEIGHT **62.0g**

表面仕上げ /SURFACE NF DP HF **HF2**

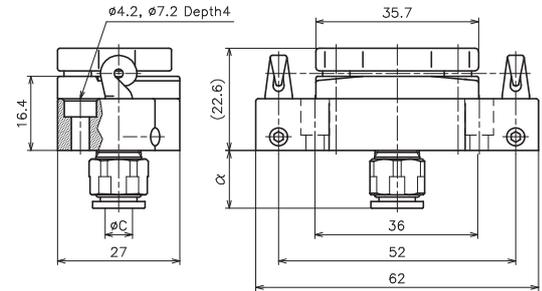

図番 /No. **C204030**



D/NO.	φd
C204030-G	1.1
C204030-H	1.2
C204030-J	1.4
C204030-L	1.6

重量 /WEIGHT **37.0g**

表面仕上げ /SURFACE NF DP HF **HF2**

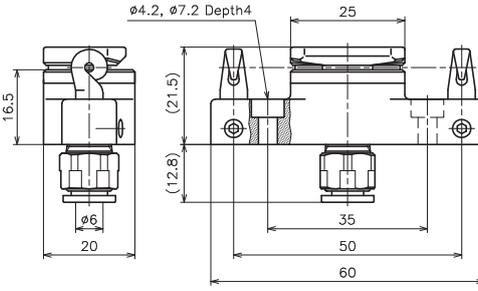

図番 /No. **D905030**



D/NO.	φd
D905030-G	2×1.1
D905030-H	2×1.2
D905030-I	2×1.3
D905030-J	2×1.4
D905030-L	2×1.6

重量 /WEIGHT **77.0g**

表面仕上げ /SURFACE NF DP HF **HF2**

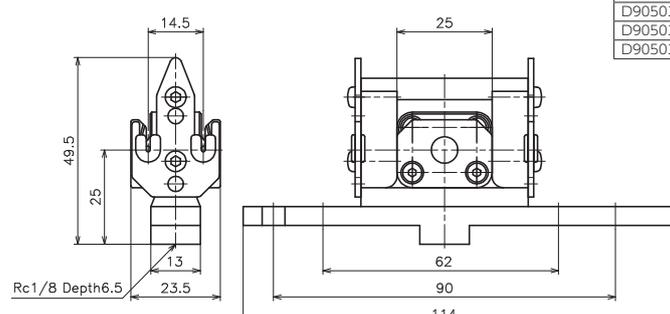

図番 /No. **D007002**



重量 /WEIGHT **20.4g**

表面仕上げ /SURFACE NF DP HF HF2

MIGRATION NOZZLE
マイグレーションノズル

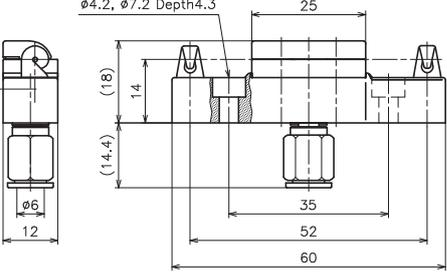

D/NO.	φd
D007002-G	1.1
D007002-I	1.3
D007002-K	1.5

HF2仕様=D003037-I(G-K)

図番 /No. **D306030**



重量 /WEIGHT **21.0g**

表面仕上げ /SURFACE NF DP HF HF2

MIGRATION NOZZLE
マイグレーションノズル

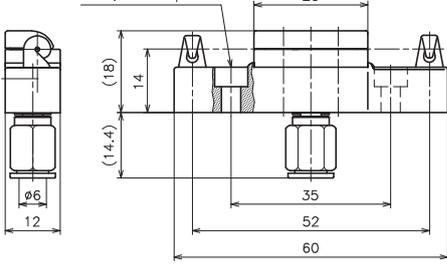

D/NO.	φd
D306030-G	1.1
D306030-I	1.3
D306030-J	1.4
D306030-K	1.5

HF2仕様=D202060-I(G-K)

図番 /No. **D412006**



重量 /WEIGHT **33.0g**

表面仕上げ /SURFACE NF DP HF HF2

MIGRATION NOZZLE
マイグレーションノズル

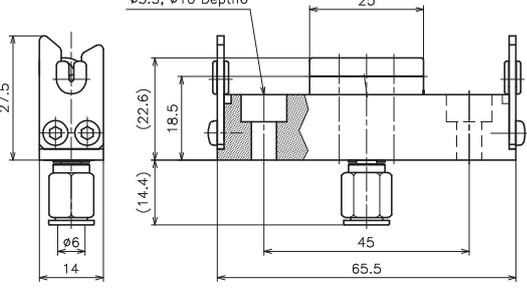

D/NO.	φd
D412006-G	1.1
D412006-I	1.3
D412006-J	1.4

HF2仕様=F004049-I(G-J)

図番 /No. **D512002**



重量 /WEIGHT **38.2g**

表面仕上げ /SURFACE NF DP HF HF2

MIGRATION NOZZLE
マイグレーションノズル

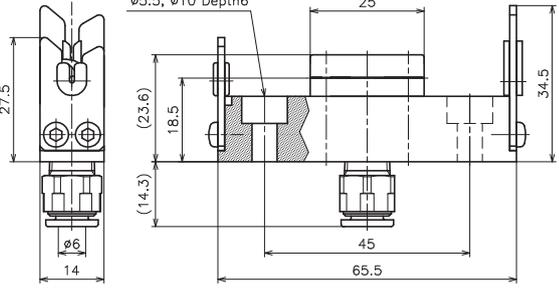

D/NO.	φd
D512002-K	1.5
D512002-L	1.6
D512002-N	1.8

HF2仕様=D803069-K(L-N)

- OILING GUIDE - INTER LACER
- TRAVEL GUIDE
- SNAIL GUIDE - DOG TAIL GUIDE
- HOOK GUIDE - SLIT GUIDE
- TWIST STOP WHEEL
- ROLLER GUIDE
- CHEEL PARTS
- GUIDE etc.
- BEARING ROLLER GUIDE
- BAR GUIDE - PIPE GUIDE
- EYELET GUIDE - TUBE GUIDE
- TENSION WASHER
- TENSOR
- YARN SENSOR
- OTHER

- QUILTING GUIDE - INTER LACER
- TRANSVERSE GUIDE
- SNAIL GUIDE - DOG TAIL GUIDE
- HOOK GUIDE - SLIT GUIDE
- TWIST STOP WHEEL
- ROLLER GUIDE
- CHEEL PARTS
- GUIDE etc.
- BEARING ROLLER GUIDE
- BAR GUIDE - PIPE GUIDE
- EYELET GUIDE - TUBE GUIDE
- TENSION WASHER
- TENSOR
- YARN SENSOR
- OTHER

図番 /No. **F401002**



重量 /WEIGHT **29.7g**

表面仕上げ /SURFACE NF DP HF HF2

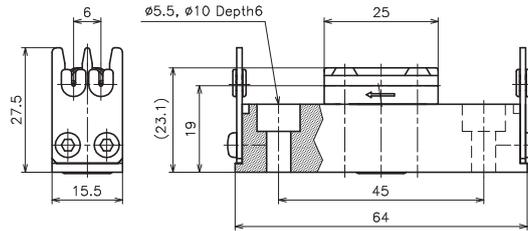

図番 /No. **D505005**



重量 /WEIGHT **41.7g**

表面仕上げ /SURFACE NF DP HF HF2

D/NO.	φd
D505005-G	1.1
D505005-I	1.3
D505005-K	1.5

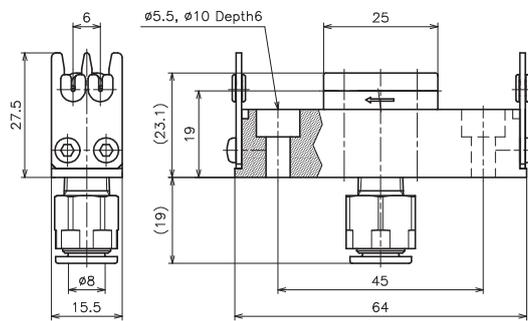

HF2仕様=F004050-I(G・K)

図番 /No. **D508035**



重量 /WEIGHT **31.4g**

表面仕上げ /SURFACE NF DP HF HF2

D/NO.	φd
D508035-G	1.1
D508035-I	1.3

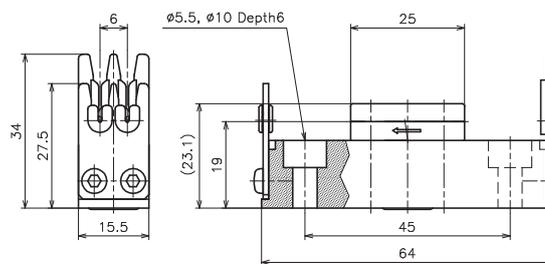

HF2仕様=F004051-I(G)

図番 /No. **D608128**



重量 /WEIGHT **41.6g**

表面仕上げ /SURFACE NF DP HF HF2

D/NO.	φd
D608128-G	1.1
D608128-I	1.3
D608128-K	1.5

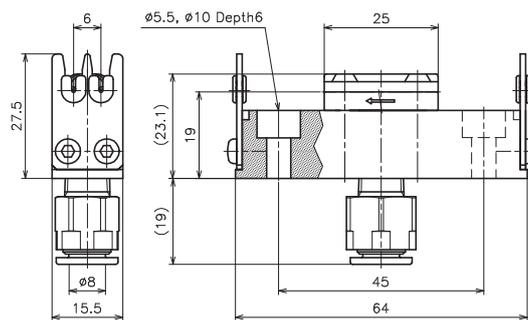

HF2仕様=F004052-I(G・K)

図番 /No. **Q204022WH**



重量 /WEIGHT **36.5g**

表面仕上げ /SURFACE NF DP HF HF2

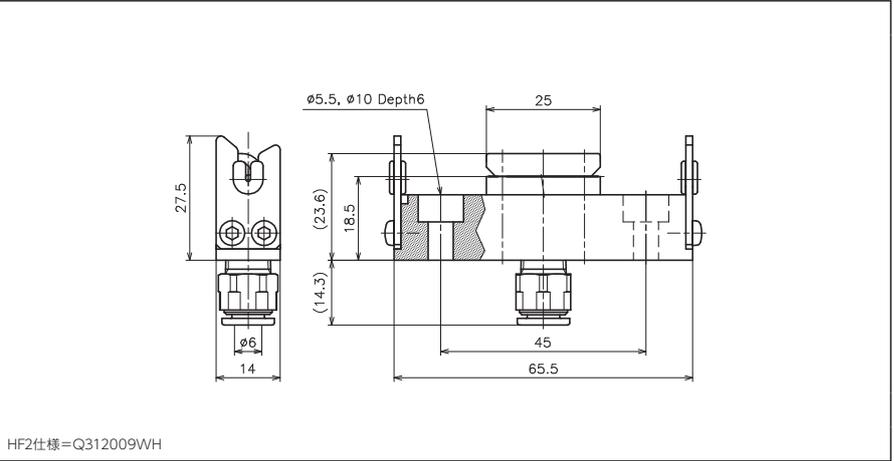

図番 /No. **F106002**



重量 /WEIGHT **35.0g**

表面仕上げ /SURFACE NF DP HF HF2

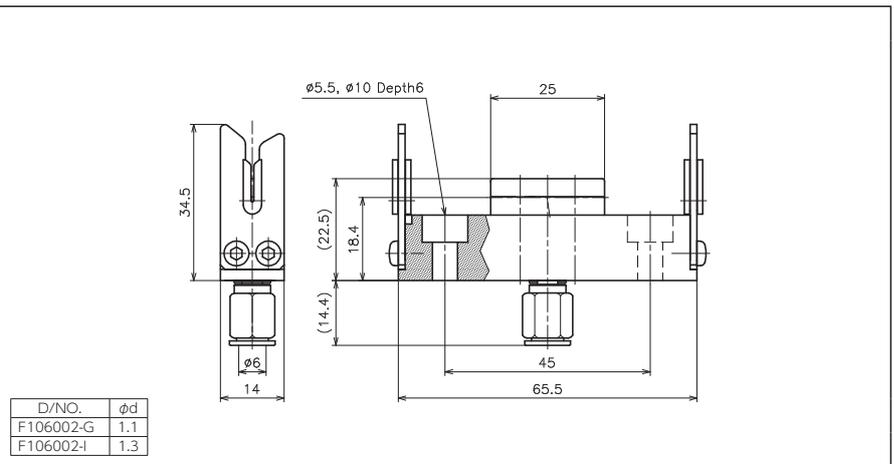

図番 /No. **F009030**



重量 /WEIGHT **43.0g**

表面仕上げ /SURFACE NF DP HF HF2

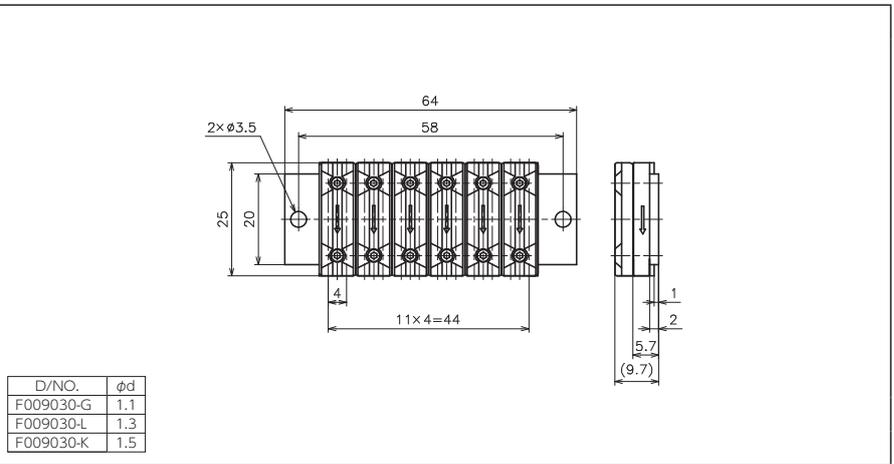

図番 /No. **D807017**



重量 /WEIGHT **124.5g**

表面仕上げ /SURFACE NF DP HF HF2

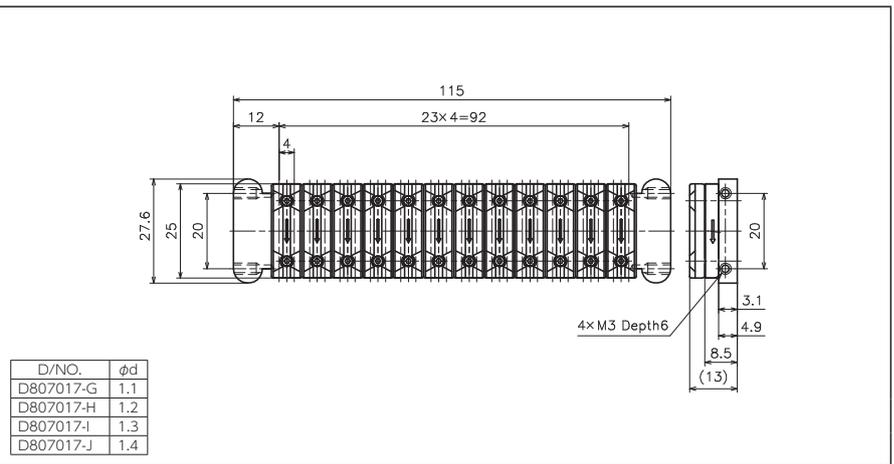

- TRAVVERSE GUIDE
- SLIT GUIDE
- WHEEL
- ROLLER GUIDE
- CHEEL PARTS
- GUIDE etc.
- BEARING ROLLER GUIDE
- BAR GUIDE-PIPE GUIDE
- EYELET GUIDE-TUBE GUIDE
- TENSION WASHER
- TENSOR
- YARN SENSOR
- OTHER

OILING GUIDE・
 INTER LACER
 TRAVERSE
 GUIDE
 SNAIL GUIDE・
 DOG TAIL GUIDE
 HOOK GUIDE・
 SLIT GUIDE
 TWIST STOP
 WHEEL
 ROLLER GUIDE
 BEARING
 ROLLER GUIDE
 CREEP PARTS
 GUIDE etc.
 BAR GUIDE・
 PIPE GUIDE
 EYELET GUIDE・
 TUBE GUIDE
 TENSION
 WASHER
 TENSOR
 YARN SENSOR
 OTHER

図番 /No. **F102006**



D/NO.	φd
F102006-G	1.1
F102006-H	1.2
F102006-I	1.3
F102006-J	1.4
F102006-K	1.5

表面仕上げ /SURFACE	NF	DP	HF	HF2

図番 /No. **D909099**

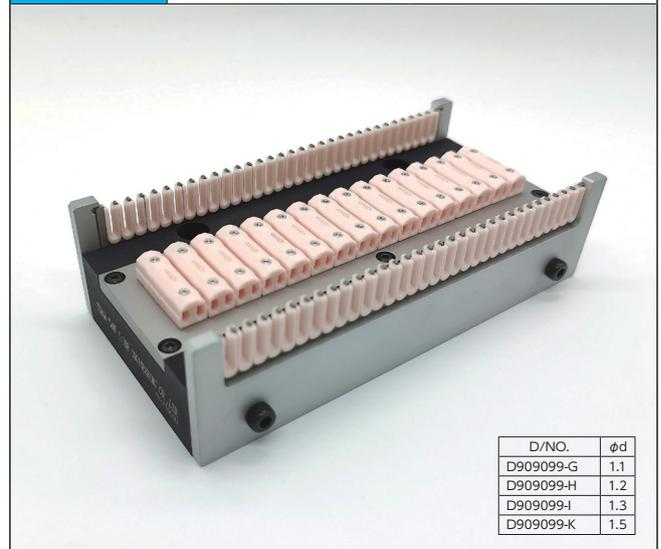

D/NO.	φd
D909099-G	1.1
D909099-H	1.2
D909099-I	1.3
D909099-K	1.5

表面仕上げ /SURFACE	NF	DP	HF	HF2

図番 /No. **D905015**



D/NO.	φd
D905015-G	1.1
D905015-H	1.2
D905015-I	1.3
D905015-J	1.4

表面仕上げ /SURFACE	NF	DP	HF	HF2

図番 /No. **F101011**

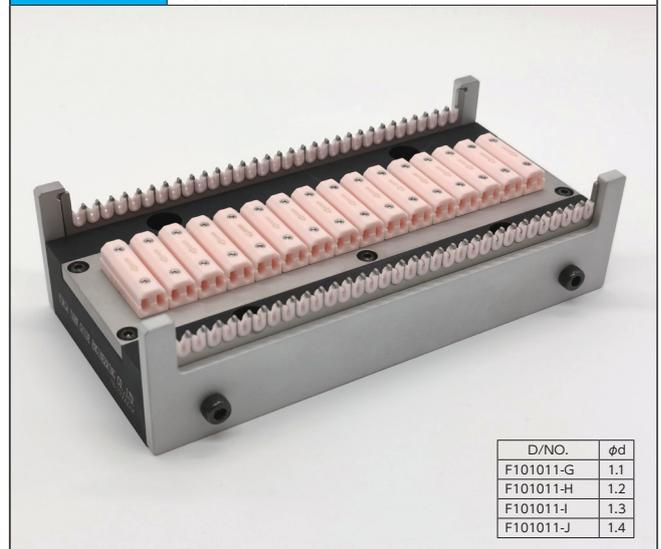

D/NO.	φd
F101011-G	1.1
F101011-H	1.2
F101011-I	1.3
F101011-J	1.4

表面仕上げ /SURFACE	NF	DP	HF	HF2

図番 /No. **F210016**

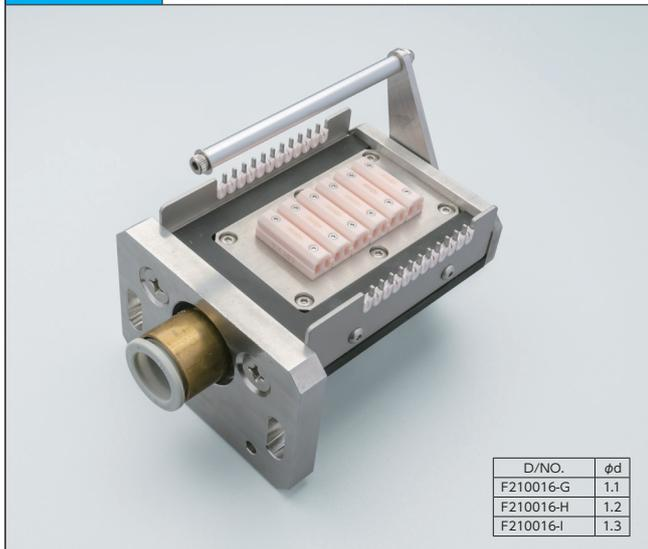

D/NO.	φd
F210016-G	1.1
F210016-H	1.2
F210016-I	1.3

表面仕上げ /SURFACE	NF	DP	HF	HF2

図番 /No. **F102025**



D/NO.	φd
F102025-G	1.1
F102025-I	1.3
F102025-J	1.4

表面仕上げ /SURFACE	NF	DP	HF	HF2